

Installation Dimensions

Type 73N, 73XL, 63, 63XL Control—Remote Sensor

Capillary Lengths:

Controls 73N, 63: 6 ½'
Controls 73NXL, 63XL: 26 ¼'

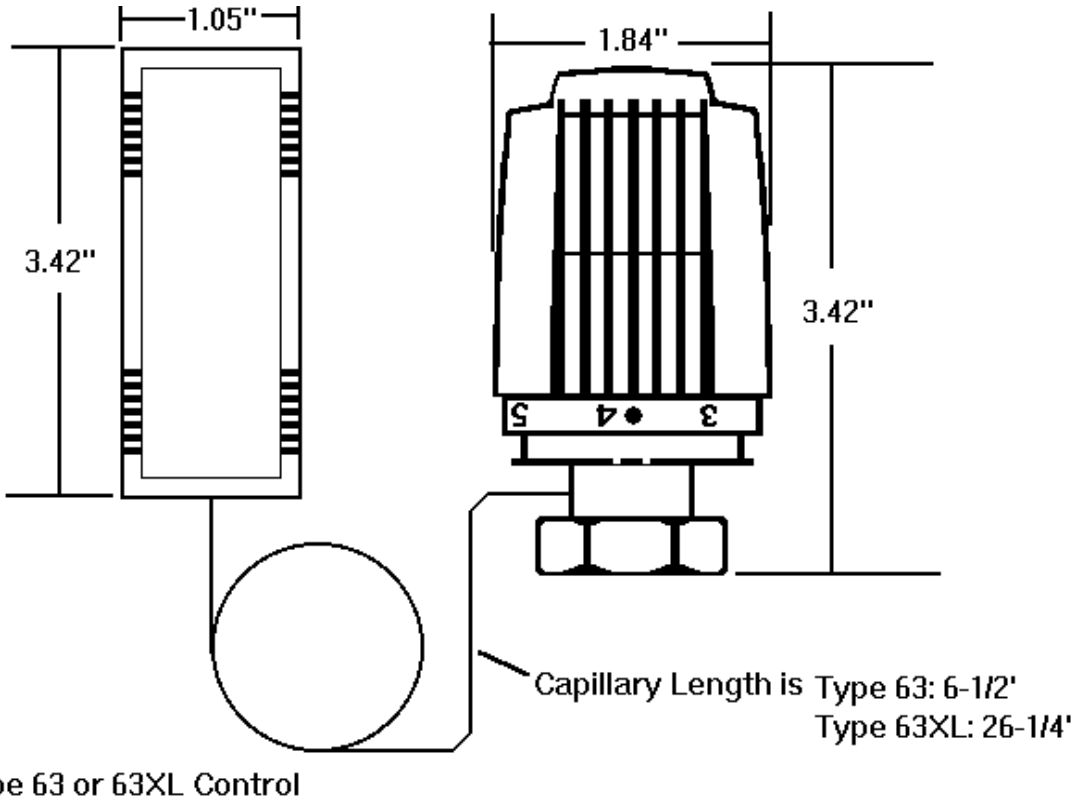

ammark
CORPORATION®

Ammark Corporation, 230 West Parkway, Unit 12, Pompton Plains NJ 07444
Phone: 800-937-0426 Fax: 973-616-0246 Email: sales@ammarkcorp.com
www.ammarkcorp.com